









AFP50

Welding
Positioner

Open the disconnect switch on the wall

Symbol	Meaning	Explain
	General	General precautions, warnings and dangers
	Be careful of hurting your hands	If you reach into the opening, you may hurt your fingers
	Note: Beware of electric shock	Electric shock may occur under certain conditions
	Device grounding	The operator must ground the device through the safety ground terminal
	Pull out the power plug from the socket	When a fault occurs or there is lightning, the operator must pull the power plug out of the socket. In case of danger!
	Pay attention to prevent explosion	An explosion may occur under certain conditions
	Arc	Pay attention to the arc
	Note: overheating!	Under certain conditions, personal injury may be caused due to high temperature
	Note: Flammable!	May ignite under certain conditions

1. Safety

1.1 Do not use outside.

1.2 Check every moving parts carefully before operation.

1.3 The operator must be trained and must hold welder certification.

1.4 Check and maintain every month to ensure that all moving parts working flexible (you must establish the inspection and maintenance records).

1.5 The mechanical parts and electrical control via the scientific design, the unauthorized modification or installation of any affiliated member.

1.6 There are high-voltage electrical control box, We must cut off the power when servicing equipment.

1.7 Regularly check the limit switch action is flexible.

1.8 Always check the slewing ring and gear is missing grease.

1.9 Instructions are to ensure safety equipment, Normal operation of the guidance document, Users in the course of which the rules must be strictly enforced, Since the violation of rules and adverse consequences, Bota disclaims any responsibility.

2. Summary

positioner is mainly used for welding circumferential weld. The main function of the workpiece is tilted, rotated so that the weld placed in the best position level, boat and other welding. The device can be fixed on the work table chuck workpiece clamping or specific tooling for use with hand soldering, But also with the welding operation machine supporting the use of automatic welding, It can also be used for cutting, grinding, assembly, testing and other processes.

The series of light displacement machine has the following characteristics:

- ◆ Applies constant torque output characteristics of DC motor drives the turntable rotates, Smooth and reliable operation of the turntable, Welding speed stepless And speed range, Adjustment of high precision.
- ◆ soft-start function.
- ◆ Equipped with the company making a special three-jaw chuck clamping convenient, Applicability, Dress can be a specially designed fixture.
- ◆ the use of foot switch control rotary table, easy to operate.

3. Technical Parameters

Model	HB-05
Input Power	AC220V 50HZ
Loading	50Kg / 25Kg
Table diameter	320mm
Table speed	1-15rpm
Flip angle	0~90°
Flip mode table	Manually
Rotating motor power	120W

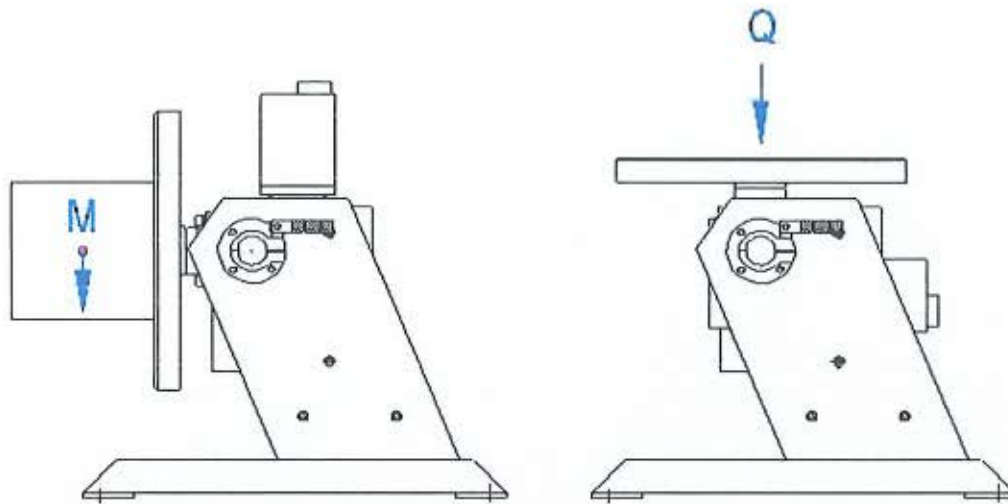

4. Device installation

4.1 A power supply box behind the power cord、 Foot switch position indication,Connect the power cord and foot switch line;And is connected to the motor connection.

4.2 Check fixtures and accessories are secure;

4.3 Input Power: Single phase 220V

5. Equipment

Before using,Ensure that each plug is properly connected and reliable,Reliable grounding wire connected with the earth,Avoid equipment damage.

5.1 Power,Power indicator light after the power switch to "POWER" opens.

5.2 In the "FOOT" control state,Press the footswitch,Rotating table,Release the foot switch,Workbench stop turning; in "AUTO" under

the control of the state, Machine into the automatic control or time control.

5.3 Convert switch to "→", the table is rotated clockwise; dial to "←", the table is rotated counterclockwise.

5.4 Rotational speed adjustment knob "SPEED" can change the table speed, clockwise rotation, Speed; Anticlockwise rotation, Slows down.

5.5 Welder ground Description: It can be directly connected to the ground wire brush, Rated current of 300A. 300A is greater than the time, Increase in parallel brushes.

5.6 The controller comes with welder linkage interface, The two-pin plugs and wire feeder two core plug, It can be achieved with welding positioner linkage.

6. Care and maintenance

6.1 Inter-product gear parts, Engaging portion between the worm to timely add the oil, Ensure the normal operation of equipment.

6.2 Regularly check the carbon brushes wear, Brush the remainder of the reach of the turntable when you want to be replaced, Ensure safe operation.

6.3 Regularly check the bearing lubrication and wear of the main axis, Lubricant in a timely manner based on usage or replaced with new bearings.

6.4 The machine can not be overloaded for a long time, Otherwise it will cause the destruction of the motor and various electrical components.

7. Electrical schematic

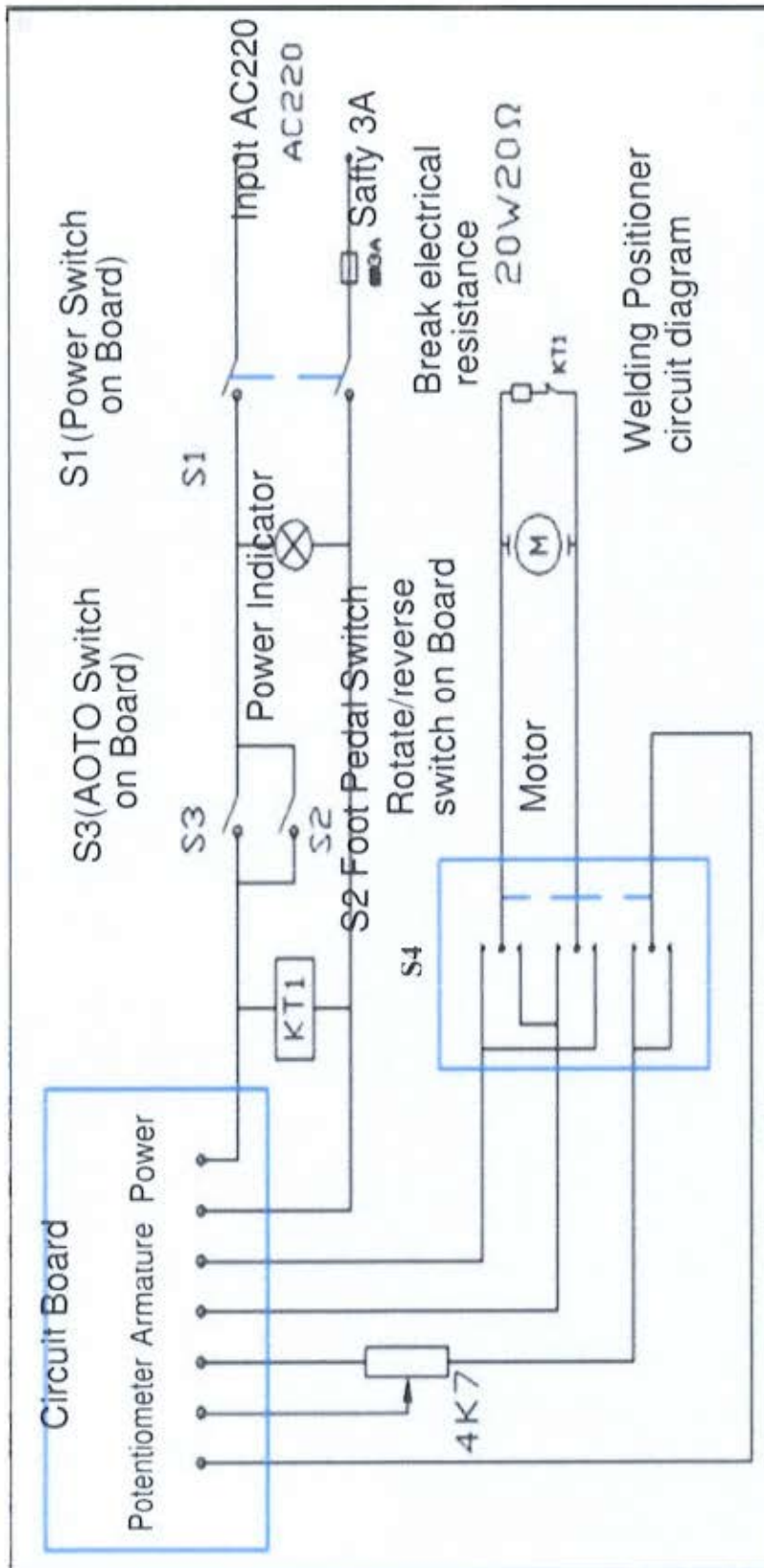

8. Fault removing

No.	Symptom	cause of issue	Method of exclusion
1	Power light is off	1. Power Insurance Skipping. 2. Indicator damage. 3. Power switch is damaged. 4. No power input.	1. Reset the power fuse (press). 2 REPLACE indicator. 3. Replace the switch. 4. maintenance input power.
2	Speed can not be adjusted	1. Speed Potentiometer damage. 2. The panel is damaged.	1. potentiometer 4.7KΩ repair or replacement. 2. Use the multimeter to check whether the board armature end DC voltage output: replace or repair the control board.
3	Foot switch out of control	1. The foot switch is damaged. 2. Parallel and foot switch toggle switch control.	1. Replace or repair the foot switch. 2. Replace or repair conversion button switch ..
4	Power switch out of control	Power switch is damaged	Replace or repair switch.
5	Motor Action	1. motor failure 2. The control panel failure 3. Switch Failure	1. Replace or repair motor. 2. Replace or repair the control board. 3. Replace or repair switch.
6	Motor reversing out of control	1, reversing switch is damaged. 2, the control board is damaged.	1, replace the switch. 2, replace or repair the control board.

Certificate of approval

Product name	Model	No
Welding Positioner	HB-05	
Inspection Items		
Rated Loading (Kg)	50kg	
Rotating Speed(rpm)	1-15 r/min	
Power (KW) Rotating	120w	
Size of working Table (mm)	Φ320mm	
Tilting speed (mm)	manual	
<p>The product accords with the technical criteria and is allowed to sell</p>		
Identifier:	Date:	

The packing list

HB05 Welding Positioner (1 set)

No.	Name	Qty	Unit	Note
1	Mainframe	1	unit	Contain motor
2	Electrical control cabinet	1	unit	
3	Foot switch	1	pc	
4	Use instruction	1	pc	