

# PIPE WELDING

## Hi Fold A Jack



- Maximum height 125 cm (49")
- Minimum height 71 cm (28")
- Folds up for storage ease
- 1,134 kg (2500 lbs) capacity
- Quick action lock washer for fast height positioning.
- Patented fall guard™ feature allows 25 mm (1") safety zone around lock washer
- 38 mm (1-1/2") acme fine adjustment thread
- Large, convenient adjustment handle

## Lo Fold A Jack



- Maximum height 89 cm (36")
- Minimum height 51 cm (21")
- Folds up for storage ease
- 1,134 kg (2500 lbs) capacity
- Quick action lock washer for fast height positioning.
- Patented fall guard™ feature allows 25 mm (1") safety zone around lock washer
- 38 mm (1-1/2") acme fine adjustment thread
- Large, convenient adjustment handle

Part No.	Description	Pur.	Pk
1 781300	Fold a jack w/ vee head	1	1
n/s 780518	Vee head only (carbon steel)	1	1
n/s 780502	Stainless steel sleeve for standard vee	1	1
2 781301	Fold a jack w/ roller head	1	1
3 781302	Fold a jack w/ bar stock	1	1
n/s 780519	Bar stock head only	1	1
4 781303	Fold a jack w/ stainless steel wheel	1	1
n/s 780517	Stainless steel wheel head only	1	1
5 781304	Fold a jack w/ stainless steel vee head	1	1
n/s 780498	Stainless steel vee head only	1	1
6 781305	Fold a jack w/ stainless steel ball transfer	1	1
n/s 780274	Stainless steel ball transfer only	1	1
7 781306	Fold a jack w/ rubber wheels roller head	1	1
n/s 780499	Rubber wheel head only (carbon steel)	1	1
8 781336	Fold a jack base only	1	1
9 780555	Ball trans hd weldment	1	1
10 780333	Safety lock washer	1	1
11 780424	Hi id jack barrel	1	1
10 780510	Lock washer id barrel	1	1
12 780552	Screw set C-110W	1	1
13 781050	Hold down device	1	1
14 781056	Chain extension	1	1

Part No.	Description	Pur.	Pk
1 781310	Lo fold a jack w/ vee head	1	1
n/s 780518	Vee head only (carbon steel)	1	1
n/s 780502	Stainless steel sleeve for standard vee	1	1
2 781330	Lo fold a jack base only	1	1
3 781313	Lo fold a jack w/ stainless steel rollers	1	1
n/s 780517	Stainless steel wheel head only	1	1
4 781311	Lo fold a jack w/ aluminium roller head	1	1
n/s 780514	Roller head aluminium head only	1	1
5 781314	Lo fold a jack w/ stainless steel vee head	1	1
n/s 780498	Stainless steel vee head only	1	1
6 781315	Lo fold a jack w/ ball transfer head	1	1
n/s 780551	Ball transfer head only (carbon steel)	1	1
7 781316	Lo fold a jack w/ rubber wheels	1	1
n/s 780499	Rubber wheel head only (carbon steel)	1	1
8 780333	Safety lock washer	1	1
9 780422	Lo id jack barrel	1	1
10 780510	Lock washer id barrel	1	1
11 780552	Screw set C-110W	1	1
12 781050	Hold down device	1	1
13 781056	Chain extension	1	1

# PIPE WELDING

## Hi Heavy Duty Jack



- 1135 kg (2502 lbs) capacity
- Strut tension plate for superior lateral support
- 25.4 mm (1") square tube base construction
- Built for heavy use & abuse
- Quick action lock washer

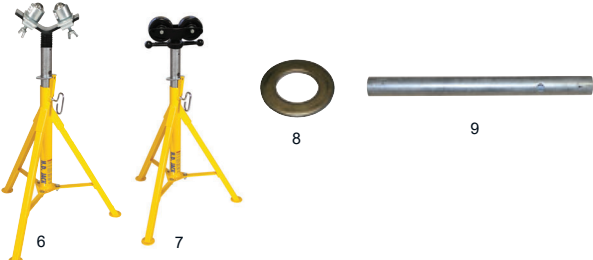

Part No.	Description	Pur.	Pk
1	780375 Hi heavy duty jack w/ vee head	1	1
2	780376 Hi heavy duty jack w/ roller head	1	1
3	780377 Hi heavy duty jack w/ bar stock head	1	1
4	780378 Hi heavy duty jack w/ SS roller	1	1
5	780379 Hi heavy duty jack w/ SS vee head	1	1
6	780380 Hi heavy duty jack w/ ball transfer head	1	1
7	780381 Hi heavy duty jack w/ rubber wheels	1	1
8	780333 Safety lock washer	1	1
9	780424 Hi id jack barrel	1	1
10	780510 Lock washer id barrel	1	1
11	780552 Screw set C-110W	1	1
12	781050 Hold down device	1	1
13	781056 Chain extension	1	1

## Lo Heavy Duty Jack



- 1135 kg (2502 lbs) capacity
- Strut tension plate for superior lateral support
- 25.4 mm (1") square tube base construction
- Built for heavy use & abuse
- Quick action lock washer
- Minimum height 510 mm (20 1/16")
- Maximum height 890 mm (35 1/16")

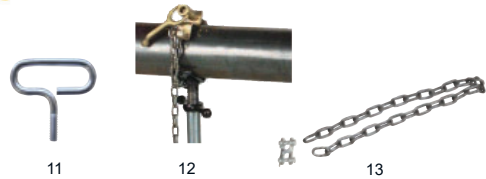
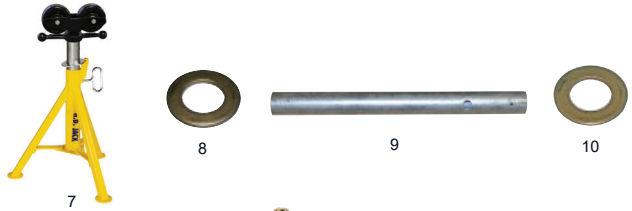

Part No.	Description	Pur.	Pk
1	780385 Lo heavy duty jack w/ vee head	1	1
n/s	780918 Ribbed vee head only	1	1
2	780386 Lo heavy duty jack w/ roller head	1	1
3	780387 Lo heavy duty jack w/ bar stock head	1	1
4	780388 Lo heavy duty jack w/ SS rollers	1	1
5	780389 Lo heavy duty jack w/ SS vee head	1	1
6	780390 Lo heavy duty jack w/ ball transfer head	1	1
7	780391 Lo heavy duty jack w/ rubber wheels	1	1
8	780333 Safety lock washer	1	1
9	780424 Id jack barrel	1	1
10	780510 Lock washer id barrel	1	1
11	780552 Screw set C-110W	1	1
12	781050 Hold down device	1	1
13	781056 Chain extension	1	1

# PIPE WELDING

## Fat Jack

- 27250 kg (6000 lbs) Vee head capacity
- 31.7 mm (1-1/4") square tube base construction
- Midi & maxi come with folding base
- Convenient carrying handle
- 177 mm (7") Vee head
- Double locking pin with retainer
- 900 mm (36") pipe capacity



Head only, purchase stand separately

Part No.	Description	Pur.	Pk
1	785250 Maxi fat jack w/ vee head & double pin	1	1
2	785251 Midi fat jack w/ vee head	1	1
3	785252 Mini fat jack w/ vee head	1	1
4	785205 Fat jack w/ roller head & double pin	1	1
5	785255 Maxi fat jack w/ roller head	1	1
6	785256 Midi fat jack w/ roller head	1	1
7	785257 Mini fat jack w/ roller head	1	1
8	785220 Fat jack roller head only	1	1
9	781376 Fat jack vee head only	1	1
10	781370 Fat jack roller head only	1	1
11	785270 Id barrel suits fat jack max	1	1
	785271 Id barrel suits fat jack mid	1	1
	785272 Id barrel suits fat jack lo	1	1
12	781050 Hold down device	1	1
13	781056 Chain extension	1	1

## Fab Saf Jack

- 1580 kg (3483 lbs) load capacity
- 760 mm 29 15/16" wide base
- 810 to 1320 mm (32" to 52") height range
- Large ribbed vee-head to accommodate 900 mm (36") pipe
- Quick action lock washer



Part No.	Description	Pur.	Pk
1	780395 Fab saf jack w/ vee head	1	1
2	780400 Fab saf jack w/ roller head	1	1
3	780424 Hi id jack barrel	1	1
4	780510 Lock washer id barrel	1	1
5	780552 Screw set C-110W	1	1
6	781050 Hold down device	1	1
7	781056 Chain extension	1	1

## Hi Boy Jack Stand

- 450 kg (992 lbs) capacity
- At it's lowest stands at 990 mm (39"), extended reaches 1830 mm (72 1/16")
- Ideal for normal fabrication of weld pipe
- Legs fold up for convenient storage
- Minimum height 980 mm (38 9/16")
- Maximum height 1800 mm (70 7/8")

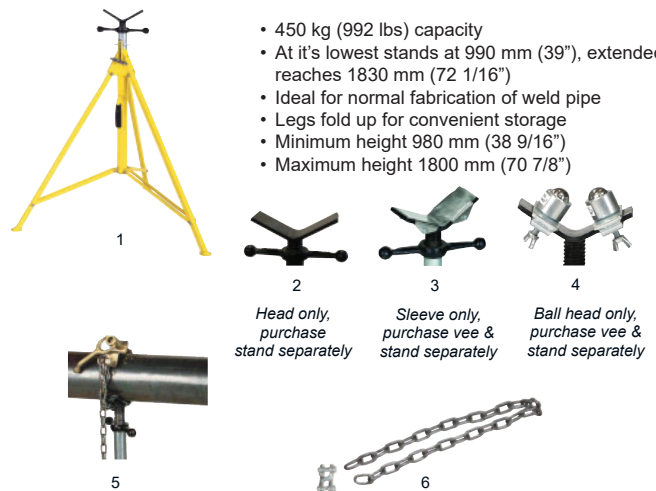

Head only, purchase stand separately

Sleeve only, purchase vee & stand separately

Ball head only, purchase vee & stand separately

Part No.	Description	Pur.	Pk
1	783250 Hi boy jack stand	1	1
2	783257 Standard vee head	1	1
3	780502 Stainless steel sleeve for standard vee	1	1
4	780551 Ball transfer head	1	1
	780274 Ball transfer head stainless steel	1	1
5	781050 Hold down device	1	1
6	781056 Chain extension	1	1

# PIPE WELDING

## Hi Pro Jack



- Formed steel legs
- 900 kg (1984 lbs) capacity
- Strut tension plate for superior lateral support
- Quick action lock washer for fast height positioning
- Patented fall guard™ feature allows 25.4 mm (1") safety zone around lock washer
- 38 mm (1-1/2") acme fine adjustment thread large, convenient adjustable handle



Part No.	Description	Pur.	Pk
1	780471 Hi pro jack w/ vee head	1	1
n/s	780518 Vee head only carbon steel	1	1
n/s	780502 Stainless steel sleeve for standard vee	1	1
2	780472 Hi pro jack w/ roller head	1	1
3	780473 Hi pro jack w/ bar stock head	1	1
n/s	780519 Bar stock head hi only	1	1
4	780474 Hi pro jack w/ SS rollers	1	1
5	780475 Hi pro jack w/ SS vee head	1	1
n/s	780498 Vee head only SS	1	1
6	780476 Hi pro jack w/ ball transfer head	1	1
n/s	780551 Ball transfer head carbon steel	1	1
n/s	780274 Ball transfer head s/s	1	1
7	780477 Hi pro jack w/ rubber wheels	1	1
n/s	780499 Rubber wheel only	1	1
8	780424 Hi id jack barrel	1	1
9	780510 Lock washer id barrel	1	1
10	780552 Screw set c-110w	1	1
11	781050 Hold down device	1	1
12	781056 Chain extension	1	1

## Heavy Duty Jack Plus



- 1135 kg (2502 lbs) capacity
- Strut tension plate for superior lateral support
- 25.4 mm (1") square tube base construction
- Built for heavy use & abuse
- Quick action lock washer
- Minimum height 710 mm (27 15/16")
- Maximum height 1250 mm (49 3/16")



Part No.	Description	Pur.	Pk
1	780326 Hi jack heavy duty w/ ribbed vee head	1	1
2	780918 Ribbed vee head only	1	1
3	780424 Hi id jack barrel	1	1
4	780510 Lock washer id barrel	1	1
5	780552 Screw set C-110W	1	1
6	781050 Hold down device	1	1
7	781056 Chain extension	1	1

## Beam Jax Basic



- 1135 kg (2502 lbs) capacity
- Clamping device enters load on stand and holds material in place while moving around shop.
- 5 leg base construction ensures stability
- Minimum clamp width of 0 mm - 610 mm (0" - 24")



Part No.	Description	Pur.	Pk
1	781485 Beam jax assembly basic	1	1
2	781486 Beam jax assembly with wheels	1	1
3	780333 Safety lock washer	1	1
4	780424 Hi id jack barrel	1	1
5	780510 Lock washer id barrel	1	1
6	780552 Screw set C-110W	1	1
7	781050 Hold down device	1	1
8	781056 Chain extension	1	1



# PIPE WELDING

## Max Jax

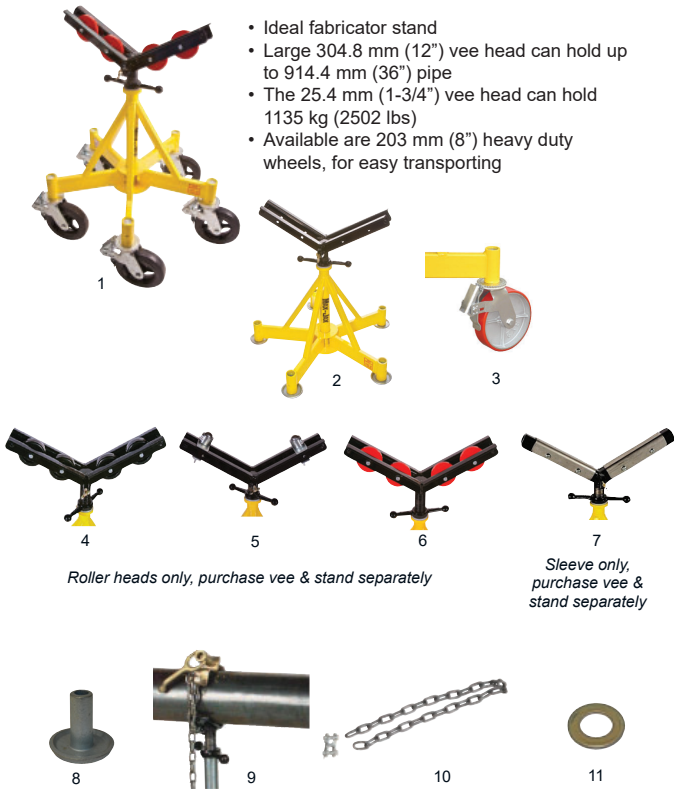

- Ideal fabricator stand
- Large 304.8 mm (12") vee head can hold up to 914.4 mm (36") pipe
- The 25.4 mm (1-3/4") vee head can hold 1135 kg (2502 lbs)
- Available are 203 mm (8") heavy duty wheels, for easy transporting

Roller heads only, purchase vee & stand separately

Sleeve only, purchase vee & stand separately

Part No.	Description	Pur.	Pk
1	781403 Max jax kit no. 1	1	1
2	781460 Basic max jax 5 legs (no wheels)	1	1
3	781465 Caster kit 5 steel casters	1	1
4	781394 Rubber roller head	1	1
5	780277 Ball transfer	1	1
6	781406 Roller head kit	1	1
7	781408 Stainless steel sleeves	1	1
8	781396 Levelling pad	1	1
9	781050 Hold down device	1	1
10	781056 Chain extension	1	1
11	781425 Thrust washer	1	1

## Big V Jack



- Built for larger pipes up to 914.4 mm (36")
- Wide base, 25.4 mm (1-3/4") acme adjustment screw and greater load capacity.
- Fast action adjustment handle
- Supports 1,135 kg (2,500 lbs)

Roller heads only, purchase vee & stand separately

Sleeve only, purchase vee & stand separately

Part No.	Description	Pur.	Pk
1	780260 Big v jack basic	1	1
2	781406 Roller head kit	1	1
3	781407 Stainless steel roller head kit	1	1
4	781394 Rubber roller head kit	1	1
5	780277 Ball transfer	1	1
6	781382 Stainless steel sleeves	1	1
7	781415 Big vee head only	1	1
8	780261 Big v base only	1	1
9	781050 Hold down device	1	1
10	781056 Chain extension	1	1

## Max Jax 2

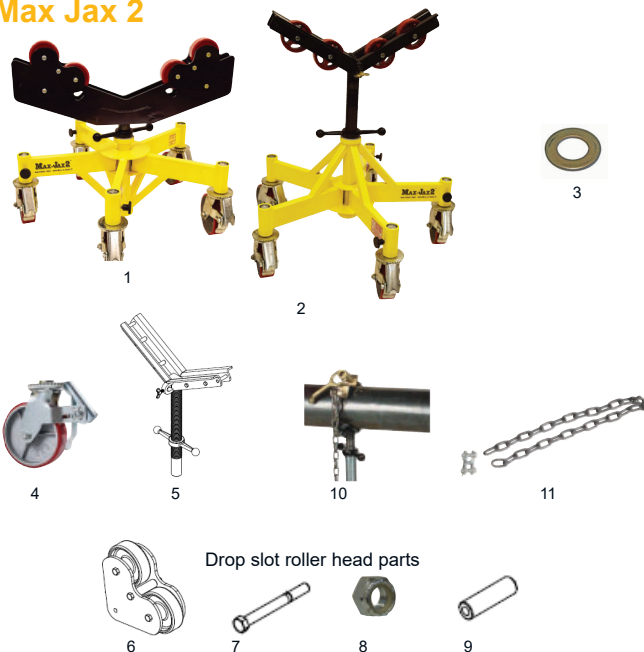

Drop slot roller head parts

Upgraded fabrication stands are the ideal high and low stand for fit-up, rotating and welding.

Designed for loads up to 2041 kgs (4,500 lbs)  
Designed to hold 10cm (4") to 91cm (36") pipe

Dual height range:  
786450: 53cm (21") to 73cm (29") low or 66cm (26") to 83cm (33") high  
786451: 54cm (21.5") to 58cm (23") low or 67 cm (26.5") to 92cm (36.5") high  
5-leg base construction with adjustable 6" casters ensure stability

Part No.	Description	Pur.	Pk
1	786451 Max jax 2 rock roller	1	1
2	786450 Max jax 2 vee	1	1
3	781425 Thrust washer	1	1
4	779048 Caster 6" swivel	1	1
5	781417 Max jax HD assembly w/spanner nut	1	1
6	786461 Drop slot housing	1	1
7	771068 Screw HHC	1	1
8	772355 Nut, insert lock	1	1
9	786471 Spacer	1	1
10	781050 Hold down device	1	1
11	781056 Chain extension	1	1
6-9	786460 Drop slot roller head	1	1

# PIPE WELDING

## Pro Roll

- Adjustable height 740 mm - 1090 mm (29 1/8" - 42 15/16")
- 12 mm - 1200 mm (1/2" - 47 1/4") or 900 kg (1984 lbs) pipe capacity
- Levelling on either side of the stand
- Uses quick change housing
- Roller housing can be changed without tools



Quick Change Roller housings can be changed in a snap, without tools, to adapt to changing job needs.

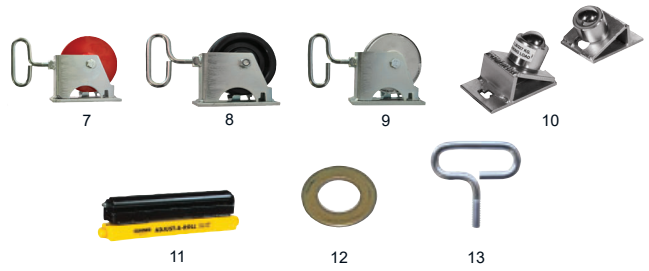

Part No.	Description	Pur.	Pk
1	780441 Pro roll w/ roller wheels	1	1
2	780442 Pro roll w/ ball transfer heads	1	1
3	780443 Pro roll w/ rubber wheels	1	1
4	780444 Pro roll w/ SS roller head	1	1
5	780446 Pro roll w/ bar stock head	1	1
6	780440 Pro roll base only	1	1
7	783151 Quick change housing w/ steel wheels	1	1
8	783152 Quick change housing w/ rubber wheels	1	1
9	783153 Quick change housing w/ SS wheels	1	1
10	783154 Quick change housing w/ ball carbon transfer	1	1
	783159 Quick change housing w/ SS ball transfer head	1	1
11	783155 Quick change housing w/ bar stock head	1	1
12	780510 Lock washer id barrel	1	1
13	780552 Screw set C-110W x 2	1	1

## Hi Adjust A Roll

- Roller adjustment from either side
- Fast adjustment for easy pipe positioning
- 12 mm - 1200 mm (1/2" - 47 1/4") or 900 kg (1984 lbs) pipe capacity
- Wheels trued for true pipe rotation
- Bronze bearing to eliminate arcing
- Brake to lock loads for layout or fit up
- Handle large enough to work with gloved hand



Quick Change Roller housings can be changed in a snap, without tools, to adapt to changing job needs.

Heads with quick change housing only, purchase stand separately

## Table Adjust A Roll

- Roller adjustment from either side
- Fast adjustment for easy pipe positioning
- 12 - 900 mm (1/2" to 36"), or 1,135 kg (2,500 lb) pipe capacity
- Wheels trued for true pipe rotation
- Bronze bearing to eliminate arcing
- Brake to lock loads for layout or fit-up

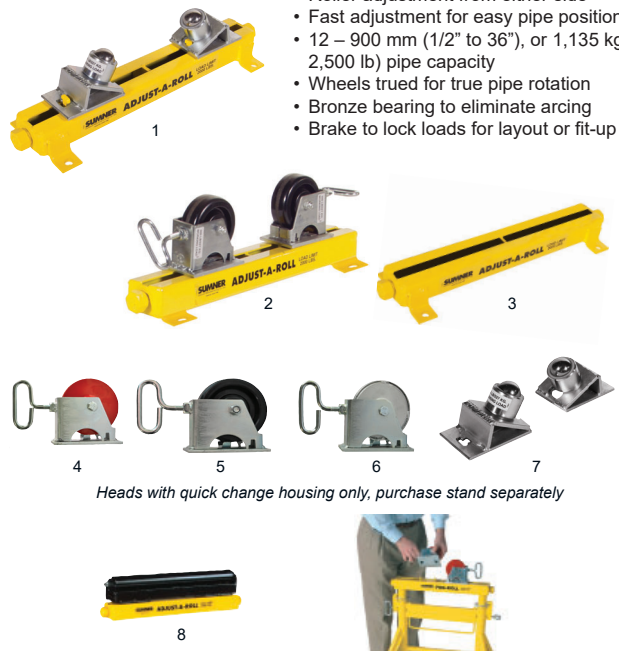

Heads with quick change housing only, purchase stand separately

Quick Change Roller housings can be changed in a snap, without tools, to adapt to changing job needs.

Part No.	Description	Pur.	Pk
1	780365 Hi adjust a roll w/ steel wheels	1	1
2	780367 Hi adjust a roll w/ rubber wheels	1	1
3	783151 Quick change housing w/ steel wheels	1	1
4	783152 Quick change housing w/ rubber wheels	1	1
5	783153 Quick change housing w/ SS wheels	1	1
6	783154 Quick change housing w/ carbon ball transfer	1	1
	783159 Quick change housing w/ SS ball transfer head	1	1
7	783155 Quick change housing w/ bar stock head	1	1
8	780552 Screw set C-110W	1	1

Part No.	Description	Pur.	Pk
1	780361 Table adjust a roll w/ ball transfer heads	1	1
2	780362 Table adjust a roll w/ rubber wheels	1	1
3	780500 Table adjust a roll base only	1	1
4	783151 Quick change housing w/ steel wheels	1	1
5	783152 Quick change housing w/ rubber wheels	1	1
6	783153 Quick change housing w/ SS wheels	1	1
7	783154 Quick change housing w/ carbon ball transfer	1	1
	783159 Quick change housing w/ SS ball transfer head	1	1
8	783155 Quick change housing w/ bar stock head	1	1

# PIPE WELDING

## Hold-E



- Grips 20 mm to 152 mm (3/4" to 6") pipe or 25 mm to 165 mm (1" to 6-1/2") tubing
- Rugged steel frame for years of use
- Quick release button allows clamp arms to open and close in seconds
- Acme threads permit positive gripping of pipe to vee head
- Operating handle repositions for close work

Part No.	Description	Pur.	Pk
785000	Hold-e pipe clamp 20 mm to 152 mm (3/4" - 6") pipe	1	1
784999	Hold-e pipe clamp stainless steel 20 mm to 152 mm (3/4" - 6") pipe	1	1

## Ultra Clamps



- A fast, accurate fit up clamp for pipe to pipe, pipe to fitting, pipe to flange and pipe to tee.
- Stainless steel contacts & alignment screws.
- Operating handle repositions for close work.
- Fine adjustment screws for quick fit up
- Lightweight for overhead work

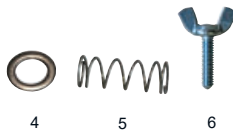

Part No.	Description	Pur.	Pk
1	781130 25 - 65 mm (1 - 2 1/2")	1	1
2	781150 50 - 150 mm (2 - 6")	1	1
3	781170 127 - 300 mm (5 - 12")	1	1
4	773016 Washer flat for 781130	1	1
	773017 Washer flat for 781150 & 781170	1	1
5	776066 Spring for 781130	1	1
	776067 Spring for 781150 & 781170	1	1
6	781147 Wing screw for 781130	1	1
	781167 Wing screw for 781150 & 781170	1	1

## Ultra Qwik Clamps



- Comes with a quick release push button
- Push button design allows for rapid action setting & fine tune threaded adjustment.
- Smooth roller clamping action for positive gripping.
- Stainless steel contacts & alignment screws

Part No.	Description	Pur.	Pk
1	781530 127 - 300 mm (5" - 12")	1	1
2	781520 50 - 150 mm (2" - 6")	1	1
3	781510 25 - 65 mm (1 - 2 1/2")	1	1

## Ultra Fit



- A fast, accurate fit up for fitting to fitting.
- Stainless steel contacts & alignment screws.
- Two hand operating handle for positive gripping
- Fine adjustment screws for quick fit up
- Lightweight for overhead work
- Smooth roller clamping action for positive gripping

Part No.	Description	Pur.	Pk
1	781265 25 - 65 mm (1 - 2 1/2")	1	1
2	781275 50 - 150 mm (2 - 6")	1	1
3	781285 127 - 300 mm (5 - 12")	1	1

## Ultra Qwik Fit



- Ultra Qwik Fit quick release button allows clamp to open & close in seconds
- Push button design allows for rapid action setting & fine tune threaded adjustment.
- Light weight for overhead work
- Stainless steel contacts & alignment screws

Part No.	Description	Pur.	Pk
1	781560 127 - 300 mm (5 - 12")	1	1
2	781550 50 - 150 mm (2 - 6")	1	1
3	781540 25 - 65 mm (1 - 2 1/2")	1	1

# PIPE WELDING

## DX Clamps



- Forged steel body tough enough to handle any use or abuse
- Adjustment screws offer hardened steel ball contact with pipe
- Five models cover 25.4 mm to 370 mm (1" to 14") pipe sizes

Part No.	Description	Pur.	Pk
781570	25 - 90 mm (1 - 3")	1	1
781571	50 - 150 mm (2 - 5")	1	1
781572	90 - 190 mm (4 - 7")	1	1
781573	125 - 225 mm (5 - 9")	1	1
781574	225 - 370 mm (10 - 14")	1	1

## Pipe Clamp



A compact, lightweight, portable clamp for the quick fit-up of round pipes and flanges for butt welding. 50-75% lighter than traditional alignment clamp. Easy to use design for the rapid, repeated loading and unloading of work pieces.

Part No.	Description	Pur.	Pk
AFQPC50	Pipe Clamp 50-100mm	1	1
AFQPC100	Pipe Clamp 100-140mm	1	1

## Pipe Clamps



Part No.	Description	Pur.	Pk
GMP6	Pipe clamp 6" (150 mm) standard tack	1	1
GMP10	Pipe clamp 10" (254 mm) standard tack	1	1

## Pipe Clamps

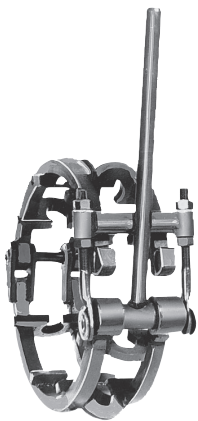

- The standard pipe clamp features a lever and a cam to tighten the clamp around both ends of adjoining pipe.
- General pipe clamps are designed for aligning pipe ends while welding.
- Hinged for easy positioning around the pipe.

Part No.	Description	Pur.	Pk
GNT04	Pipe clamp 4" (101 mm) standard no tack	1	1
GNT06	Pipe clamp 6" (150 mm) standard no tack	1	1
GNT08	Pipe clamp 8" (200 mm) standard no tack	1	1
GNT10	Pipe clamp 10" (250 mm) standard no tack	1	1
GNT12	Pipe clamp 12" (300 mm) standard no tack	1	1
GNT14	Pipe clamp 14" (355 mm) standard no tack	1	1
GNT18	Pipe clamp 18" (457 mm) standard no tack	1	1

# PIPE WELDING

## Saw Guide Pipe



Part No.	Description	Pur.	Pk
1 TSG500P	Saw guide pipe .5" (12.5 mm)	1	1
TSG750P	Saw guide pipe .75" (19 mm)	1	1
TSG1P	Saw guide pipe 1" (25 mm)	1	1
TSG125P	Saw guide pipe 1.25" (31 mm)	1	1
TSG15P	Saw guide pipe 1.5" (38 mm)	1	1
TSG2P	Saw guide pipe 2" (50 mm)	1	1
TSG25P	Saw guide pipe 2.5" (63 mm)	1	1
TSG3P	Saw guide pipe 3" (75 mm)	1	1
TSG4P	Saw guide pipe 4" (100 mm)	1	1
TSG6P	Saw guide pipe 6" (150 mm)	1	1
2 TSGPKIT1-4	Saw guide kit pipe 1-4" (25 - 100 mm)	1	1

## Tack Clamp



Part No.	Description	Pur.	Pk
1 TSTC375	Tack clamp tube 3/8" (9.5 mm)	1	1
TSTC500	Tack clamp tube 1/2" (12 mm)	1	1
TSTC750	Tack clamp tube 3/4" (19 mm)	1	1
TSTC1	Tack clamp tube 1" (25 mm)	1	1
TSTC1500	Tack clamp tube 1.5" (38 mm)	1	1
TSTC2	Tack clamp tube 2" (50 mm)	1	1
TSTC2500	Tack clamp tube 2.5" (63 mm)	1	1
TSTC3	Tack clamp tube 3" (75 mm)	1	1
TSTC4	Tack clamp tube 4" (100 mm)	1	1
TSTC6	Tack clamp tube 6" (150 mm)	1	1
2 TSTCKIT1-4	Tack clamp tube 1-4" (25 - 100 mm)	1	1

## Saw Guide Tube



Part No.	Description	Pur.	Pk
1 TSG500T	Saw guide tube .5" (12.5 mm)	1	1
TSG750T	Saw guide tube .75" (19 mm)	1	1
TSG1T	Saw guide tube 1" (25 mm)	1	1
TSG125T	Saw guide tube 1.25" (31 mm)	1	1
TSG15T	Saw guide tube 1.5" (38 mm)	1	1
TSG2T	Saw guide tube 2" (50 mm)	1	1
TSG25T	Saw guide tube 2.5" (63 mm)	1	1
TSG3T	Saw guide tube 3" (75 mm)	1	1
TSG4T	Saw guide tube 4" (100 mm)	1	1
TSG6T	Saw guide tube 6" (150 mm)	1	1
2 TSGTKIT1-4	Saw guide kit tube 1-4" (25 - 100 mm)	1	1



# PIPE WELDING

## Clamp Champ



1



2



3

- A standard kit consists of metal carrying box, main block & chain, jack bars & instructional manual.
- Large clamp champ includes double jack screws for reforming 20 mm (13/16") pipe wall.
- A conversion kit consists of chain & jack bars in increase clamp champ capacity.

Part No.	Description	Pur.	Pk
1	781000 Standard 25.4 mm - 254 mm (1" - 10") kit (3 jack bars)	1	1
	780999 Stainless steel 25.4 mm - 254 mm (1 - 10") kit (3 jack bars)	1	1
	780998 Standard 25.4 mm - 406.4 mm (1 - 16") kit (5 jack bars)	1	1
	780997 Stainless steel 25.4 mm - 406.4 mm (1 - 16") kit (5 jack bars)	1	1
	781250 Standard 254 mm - 914 mm (10 - 36") kit (7 jack bars)	1	1
	781251 Stainless steel 254 mm - 914 mm (10 - 36") kit (7 jack bars)	1	1
2	780998-031 Clamp champ 25.4 mm - 558 mm (1-22") (5 jack bars)	1	1
3	781031 Conversion kit 254 mm - 406.4 mm (10 - 16") (2 jack bars)	1	1

## Fit Kit



1

- Kit includes:
- 1 x Ultra clamp (781150) 50.8 mm - 152 mm (2" - 6")
- 1 x Ultra fit (781275) 50.8 mm - 152 mm (2" - 6")
- 1 x Internal fit up clamp (784102) 101.6 mm - 203 mm (4" - 8")
- 1 Set of carbon steel flange pins (780430)
- 1 x Level (58281640)
- 1 x Sturdy metal tool box for storage



2

- Kit includes:
- 4 x Fold a jack (781300)
- 1 x Ultra clamp (781150) 50.8 mm - 152 mm (2" - 6")
- 1 x Ultra clamp (781170) 127 mm - 304.8 mm (5 - 12")
- 1 x Ultra fit (781275) 50.8 mm - 152 mm (2" - 6")
- 1 x Ultra fit (781285) 127 mm - 304.8 mm (5 - 12")
- 1 x Internal fit up clamp (784100) 50.8 mm - 101.6 mm (2 - 4")
- 1 x Internal fit up clamp (784102) 101.6 mm - 203 mm (4 - 8")
- 1 x Internal fit up clamp (784103) 203 mm - 304.8 mm (8 - 12")
- 1 x Level (58281640)
- 1 x Steel square (781920)
- 1 x Set of quik pins (781235)
- 1 x Weld box 3617 (779928)

Part No.	Description	Pur.	Pk
1	780324 Fit kit small 50.8 mm - 152 mm (2 - 6")	1	1
2	780315 Fit kit large 50.8 mm - 304.8 mm (2 - 12")	1	1

# PIPE WELDING

## Internal Aligner Tool

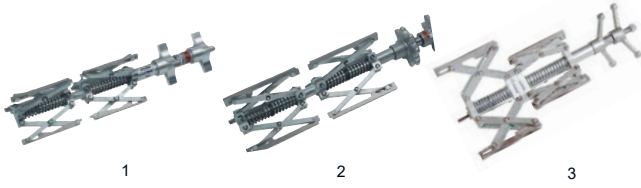

- Can be used on all standard weld neck flanges and great with slip on flanges
- One piece construction
- Quick action operation
- Stainless steel contact points

Part No.	Description	Pur.	Pk
1 784100	Internal align tool 51 - 100 mm (2 - 4") pipe	1	1
2 784102	Internal align tool 100 - 200 mm (4 - 8") pipe	1	1
3 784103	Internal align tool 200 - 300 mm (8 - 12") pipe	1	1

## Pipe Flange Aligner



Aids in fast, accurate pipe construction with self-determining flange aligning tool.

Part No.	Description	Pur.	Pk
C0721-0009	Pipe flange aligner (14779)	1	1

## Quik Pins



Part No.	Description	Pur.	Pk
781235	Qwik pin pair 16 - 42 mm (5/8" - 1 5/8") holes	1	1

## Flange Pins



Part No.	Description	Pur.	Pk
1 780650	Flange pins pair 38 - 66 mm (1 1/2" - 2 5/8") holes	1	1
2 780429	Stainless steel flange pin	1	1
3 780430	Flange pin	1	1

## Two Hole Pins Magnetic



- Faster
- No more threads to damage
- No nuts that need to be screwed on

Just place in flange holes and the nuts and pins bond together immediately with fastest magnetic speed possible.



The magnetic mini pins will self-align on holes from 7.9 mm to 22 mm (5/16" to 7/8") diameter and will work on flanges from 11 mm to 22 mm (7/16" to 7/8") thick.

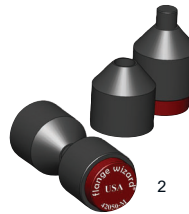

The magnetic standard pins will self-align on holes from 5.08 mm to 36.5 mm (1/2" to 1-7/16") diameter and will work on flanges from 15.8 mm to 38.1 mm (5/8" to 1-1/2") thick.

Part No.	Description	Pur.	Pk
1 42050MM	Flange 2 hole pins magnetic mini	1	1
2 42050M	Flange 2 hole pins magnetic standard	1	1
42050ML	Flange 2 hole pins magnetic large	1	1

## Two Hole Pins



42050TW - Fits 12.7 mm to 36.5 mm (1/2" to 1-7/16") flange holes

42050-TL-W - Fits 12.7 mm to 49.2 mm (1/2" to 1-15/16") flange holes

42050-TXL-W - Fits 15.8 mm to 76.2 mm (5/8" to 3") flange holes

42050TM - Fits 8 mm to 25 mm (5/16" to 63/64") flange holes  
Stud has a 5/16-18 thread.

Part No.	Description	Pur.	Pk
42050TW	Flange 2 hole pins threaded	1	1
42050-TL-W	Flange 2 hole pins large threaded	1	1
42050-TXL-W	Flange 2 hole pins extra large threaded	1	1
42050TM	Flange 2 hole pins small threaded	1	1

# PIPE WELDING

## Pipe Flange Aligners



1

38240TW has threaded pins for flanges to 760 mm (30") - 68 kgs (150 lbs). Fits flanger with holes up to 1-7/16" diameter x 2-1/2" thick. 1/2-13 double lead studs - 8" center to center. Aligner bar is 10" long.

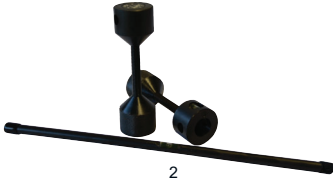

2

38240TL-W fits flanges with holes up to 1-15/16" in diameter x 4" thick. 1/2-13 double lead studs - 15" center to center. Aligner bar is 18" long.



3

38240-MAK will fit flange holes from 12.7 mm to 49 mm (1/2" to 1-15/16"). Aligns horizontally & vertically off the steel face of the flange. The on/off 40 kg (88 lbs) magnet makes this tool the fastest and easiest flange aligner to use in the industry. The centering cones can also be used as nuts if the flanges are made of a non-ferrous material.

Part No.	Description	Pur.	Pk
1	38240TW	1	1
2	38240-TL-W	1	1
3	38240-MAK	1	1

## Flange Leveler



1



2

Part No.	Description	Pur.	Pk
1	781240	1	1
2	779934	1	1

## Pro-Pipe Flange Alignment Tool



Save on fit up time and eliminates having to balance to level on fit up pins.

Part No.	Description	Pur.	Pk
PPFAT-1	Flange aligner tool Pro-pipe	1	1

## Vial Repair Kit



For quick on the job repairs for any of our tools that have levelling vials. Kit includes two vials and one tube of sealant.

Part No.	Description	Pur.	Pk
5102W	Vial repair kit	1	1

## Adjust A Fit



- Easy to line up fittings
- Uses gravity to bring fittings for loads up to 45°
- Fastens directly onto fittings for loads up to 450 kgs (992 lbs)
- Threaded shaft assembly is hardened for long tool life

Part No.	Description	Pur.	Pk
780420	Adjust a fit	1	1

## Adjust A Flange



- Fits all flanges for 127 mm (5") pipes and larger with bolt holes 19 to 42 mm (3/4" to 1 5/8")
- Handles loads up to 450 kgs (992 lbs)
- Flange nuts serve as convenient reference points to check level

Part No.	Description	Pur.	Pk
780425	Adjust a flange	1	1

## Flange Aligner Base



Removes the difficulty of flange aligning and squaring. Tool holds a square in the needed position without tying up one's hands.

Part No.	Description	Pur.	Pk
C0721-0029	Flange aligner base (14795)	1	1

# PIPE WELDING

## Flange Spreader

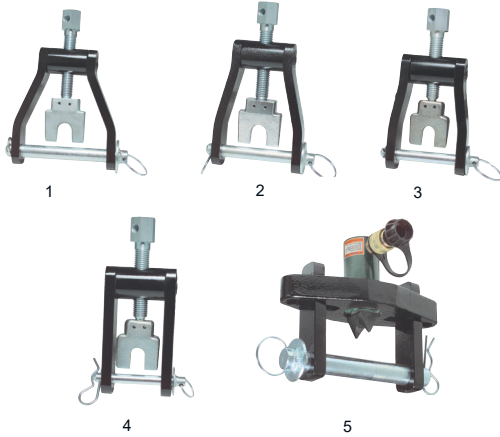

- Cover flange ranges from 25 mm to 600 mm (1" to 23 5/8")
- Can be used for 68 kgs to 680 kgs (150 to 1,500 lbs) flanges
- Hardened wedge for safe splitting
- Large feed screw
- Drive can be rotated by 25.4 mm (1-3/8") wrench or 12.7 mm (1/2") bar
- Compact design – strong enough for tough jobs

Part No.	Description	Pur.	Pk
1 784000	162 mm (6 3/8") spread, 25 mm (1") pin diameter	1	1
2 784001	127 mm (5") spread, 22 mm (7/8") pin diameter	1	1
3 784002	101 mm (4") spread, 19 mm (3/4") pin diameter	1	1
4 784003	76 mm (3") spread, 16 mm (5/8") pin diameter	1	1
5 784004	70 - 215 mm (2 3/4" - 8 7/16") spread hydraulic	1	1

## Centering Head

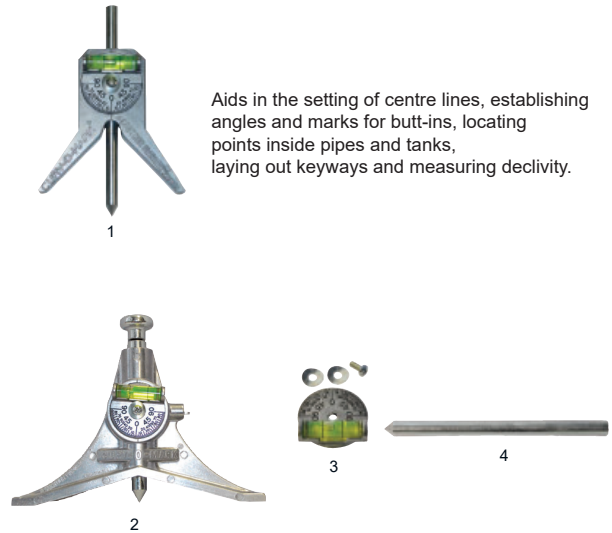

Aids in the setting of centre lines, establishing angles and marks for butt-ins, locating points inside pipes and tanks, laying out keyways and measuring declivity.

Part No.	Description	Pur.	Pk
1 C0721-0005	Centering head standard	1	1
2 C0721-0006	Centering head jumbo	1	1
3 C0722-0000	Dial set level (14797)	1	1
4 C0722-0001	Centering pin	1	1

## Magnetic Centering Heads



Magnetic "Y" small shaped body  
The addition of the magnets are the legs. Use it to establish and mark a center line at any angle around the circumference on a pipe or tank.



Standard magnetic centering head with its one piece "Y" shaped body is designed to establish and mark a center line at any angle.



Large magnetic centering head with its one piece "Y" shaped body only wider and larger. The wide-spread body has two strong magnets in each leg for maximum holding power.

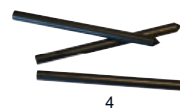

Replacement pin for the Centering Heads



For pipes 3" and larger) is designed to establish and mark a center-line at any angle around the circumference (inside and out) on a pipe or tank.

Part No.	Description	Pur.	Pk
1 53025MW	Magnetic centering head small	1	1
2 53076MW	Magnetic centering head standard	1	1
3 53085M	Magnetic centering head large	1	1
4 2311-L-W	Centre punch pin	1	1
5 53077D	Magnetic centering head digital	1	1

# PIPE WELDING

## Digital Inclinometer



- Fixed magnetic arms accommodate 4" to 8" steel pipe or tank.
- Push button spring-loaded striking hammer
- Alignment marks for centering
- Digital gauge can be used as angle finder



2

Part No.	Description	Pur.	Pk
1 784520	Center punch w/ digital inclinometer in case	1	1
2 779546	Inclinometer digital for center punch	1	1

## Multi Angle & Square Attachment



Works with Miter Marker MMS505 and Master Marker MML510.

Part No.	Description	Pur.	Pk
MAA520	Multi angle & square attachment	1	1

## Centre Punch



- Adjustable arms accommodate 101 mm (4") to any size steel pipe or tank
- Magnetic base
- Push button spring loaded striking hammer
- Removable digital gauge with magnetic base
- Alignment marks for centering
- Digital gauge can be used as angle finder

Part No.	Description	Pur.	Pk
784590	Uni centre punch	1	1

## Rotary Ground Clamp

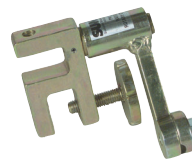

- Rotary head turns with the pipe.
- Attaches & detaches in seconds.
- Makes up ground leads three ways lug, clamp on and bare cable.
- Positive anti arc bearings take loads up to 400 amps.

Part No.	Description	Pur.	Pk
780435	Rotary ground clamp	1	1

## Angle Magnetic Fixtures



1

Holding capacity: 12.5 kgs  
Angles: 30, 45, 60, 75, 90  
Size: 96 x 14 x 54 mm



2

Holding capacity: 41.0 kg  
Angles: 45, 90, 135  
Size: 160 x 20 x 102 mm

Part No.	Description	Pur.	Pk
1 781885	Multiple angle fixture	1	1
2 781887	Medium angle fixture	1	1

## Pipe Ground Clamp

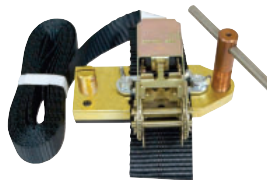

- Amperage: 600
- Will work on any pipe
- Insulated pads won't damage or arc on pipe coatings
- Tightens with 3 m (10') web strap (included) which will fit up to 1.8 m (6') diameter pipe.
- Strap width 25 mm (1") flame retardant 90° C maximum working temp.
- Weight 1.3 kg

Part No.	Description	Pur.	Pk
CPG400	Pipe ground clamp 400 amp	1	1



# PIPE WELDING

## Levels



1

A twin vial level constructed of tough ABS and aluminium frame, the strong magnetic base makes this pocket size level great for many tasks.



2

Rugged die cast aluminium  
0°, 45°, 90° acrylic vials  
25 cm (10") torpedo level  
0.5 mm/m (.0005"/inch) accuracy  
Earthen magnetic base



3

- 0°, 45°, and 90° set vials
- Lightweight aluminum construction
- V-grooved edge helps hold the level in place on pipe or conduit
- Water and impact resistant

Part No.	Description	Pur.	Pk
1	781947	Pocket level	1 1
2	781950	Accu-level	1 1
3	58281640	Conduit Bending Level	1 1

## Pocket Degree Level



This pocket size, combination degree level makes it easy to establish angles and mark for butt-ins, set tanks, layout keyways and measure decline or slope.

Part No.	Description	Pur.	Pk
L-2-W	Pocket degree level	1	1

## Dial Angle Flange Level



1

2

A versatile tool that can be used as a dial degree utility level or, with attachments, for two holding flange alignment. Fitted with a threaded, self aligning conical spacer & conical nut & bolt units for fastening the level to a pipe flange.

Part No.	Description	Pur.	Pk
1	C0721-0017	Dial angle flange level	1 1
2	C0722-0000	Dial set level (14797)	1 1

## Pocket Pro Level



Extra strong magnets hold it firmly to any steel surface. There are two stationary vials placed at 90° angles of each other and can be read from any surface of the level.

Part No.	Description	Pur.	Pk
PP200W	Pro pocket level	1	1

## Promag Level



1

2

A lightweight, easy to use tool for determining angles. Unit is ideal for anyone who has to determine angles or do setup work

Part No.	Description	Pur.	Pk
1	C0721-0007	Promag level (14777)	1 1
2	C0722-0000	Dial set level (14797)	1 1

## Pocket Level Standard



Standard pocket level is machined from aircraft quality aluminium and anodized for lasting protection. Designed for tradesman who only needs a three position level.

Part No.	Description	Pur.	Pk
SL100-W	Pocket level standard	1	1

## Universal Level



1

2

Designed primarily for pipe fitting applications, the universal level is a valuable tool for any craft required to use a level or a plumb bob.

Part No.	Description	Pur.	Pk
1	C0721-0030	Universal level (14796)	1 1
2	C0722-0000	Dial set level (14797)	1 1

# PIPE WELDING

## Miter Marker On/Off Magnet



For 203 mm to 1219 mm (8" to 48") pipe and 1219 mm (48") structural beams. Ideal for structural beam layouts and marking angles or saddles on pipe and tubing. Allows you to telescope out over existing welds to layout angles or change the angles of pipe fittings to meet your special needs. It has its own 360° rotating shaft with a built-in levelling vial.

Part No.	Description	Pur.	Pk
MMS505	Mitre marker on/off magnet	1	1

## Miter Marker Imager Mag Combo



Two complete tools in one case. Miter marker arm assembly for size range 38 mm to 457 mm (1-1/2" to 18") pipe & 457 mm (18") structural beams. Multi hole imager tower assembly for elongated holes in plate or ellipse holes in pipe at any angle up to 457 mm (18"). Both have a 68 kg pull on/off magnetic body.

Part No.	Description	Pur.	Pk
MMC505	Mitre marker imager mag combo	1	1

## Master Marker On/Off Magnet



For 203 mm to 1219 mm (8" to 48") pipe and 1219 mm (48") structural beams. Ideal for structural beam layouts and marking angles or saddles on pipe and tubing. Telescope out over existing welds to layout angles or change the angles of pipe fittings to meet your special needs. Includes a 360° rotating shaft with a built-in levelling vial.

Part No.	Description	Pur.	Pk
MML510	Master marker on/off magnet	1	1

## Master Marker Imager Mag Combo



Master marker arm assembly for size range 203 mm to 1219 mm (8" to 48") pipe and 1219 mm (48") structural beams. Multi hole imager tower assembly for elongated holes in plate or ellipse holes in pipe at any angle up to 457 mm (18"). Both have a 68 kg pull on/off magnetic body.

Part No.	Description	Pur.	Pk
MMC510	Master marker imager mag combo	1	1

## Multi Hole Imager On/Off Magnet



The strong "on and off" magnet makes positioning on a round, flat, or irregular surface easy. Built in levelling vial in the main tower. The multi-hole imager will layout round or elongated holes (ellipse) on flat material or pipe to match laterals at compound angles or at 90°. A protractor, with adjustable shaft and sliding marking arm, fits in the main arm of the Imager allowing for layout of elliptical holes in header pipe for matching compound pipe laterals coming in to the header. It will layout matching holes in pipe for 90° saddle branches.

Part No.	Description	Pur.	Pk
MHI515	Multi hole imager on/off magnetic	1	1

## Circle Ellipse Projector

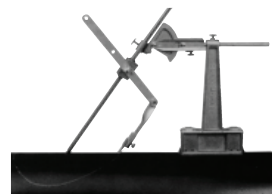

Ideal for creating perfect circles, ellipses or oblong circles on any irregular flat or round surface. Can be used to lay out lateral intersections.

Part No.	Description	Pur.	Pk
C0721-0014	Circle ellipse projector (14787)	1	1

# PIPE WELDING

## Radius Markers



The wizard radius markers are precision tools. Three sizes to choose from to mark your smallest circles to the large ones, up to 100" in diameter.

Part No.	Description	Pur.	Pk
72800W	Radius marker small	1	1
72805W	Radius marker medium	1	1
72810W	Radius marker large	1	1

## Contour Marker



Ideal for quick, precise layout of laterals at any angle, tees, wyes, crosses, elbows any type or size of joint.

Part No.	Description	Pur.	Pk
C0721-0000	Contour marker (14771)	1	1

## Contour Marker Jumbo



Developed for use in the layout of large diameter pipe, from (200 mm to 1210 mm (8" to 48")). Comes complete with a durable web strap to help hold the unit in place.

Part No.	Description	Pur.	Pk
C0721-0003	Contour marker jumbo (14773)	1	1

## Fitter Welder Protractor



90° protractor has a matching locking lever to set and hold the tool at the desired angle.

Part No.	Description	Pur.	Pk
C0721-0008	Fitter welder protractor	1	1

# PIPE WELDING

## Pipe Magician Case



- 1 - Pipe flange aligner # 38240-T
- 1 - Standard magnetic centering head # 53076-M
- 1 - Pocket pro level # PP-200
- 1 - Small wizard wrap # WW-16
- 1 - Flange wizard tools catalogue
- 1 - FREE Vial repair kit # 5102

Part No.	Description	Pur.	Pk
8905	Pipe magician case	1	1
8905M	Pipe magician case magnetic	1	1

## Wizard Wrap

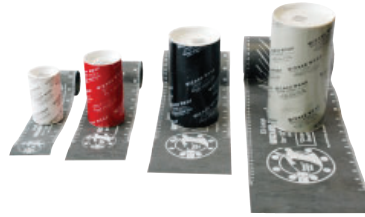

Wizard wrap is made from a non asbestos, heat resistant material. Edges are sanded and straight for easier more accurate marking.

Part No.	Description	Pur.	Pk
WW16W	Small 25 - 152 mm (1" - 6")	1	1
WW17W	Medium 50 - 406 mm (2" - 16")	1	1
WW17AW	Large 152 - 762 mm (6" - 30")	1	1
WW19W	Extra large 304 - 1219 mm (12" - 48")	1	1

## Wizard Burning Guides Case



- 1 - Plasma beveling cutting guide #PBG-601-11
- 1 - Magnetic base w/ straight pin & suction cups #77350
- 2 - Magnetic blocks #MSB202
- 1 - Magnetic tape holder #89754

Part No.	Description	Pur.	Pk
8910-P	Wizard burning guides	1	1

## Pro Pipe Wrap



Part No.	Description	Pur.	Pk
PP164	Small Pro Pipe Wrap 99 x 1209 mm size (3.9" x 47.6") Suits 76 - 152 mm (3" - 6") Pipe Diameter	1	1
PP176	Medium Pro Pipe Wrap 99 x 1808 mm size (3.9" x 71.2") Suits 76 - 254 mm (3" - 10") Pipe Diameter	1	1
PP177	Large Pro Pipe Wrap 127 x 2128 mm size (5.0" x 83.8") Suits 101 - 304 mm (4" - 12") Pipe Diameter	1	1
PP179	XL Pro Pipe Wrap 127 x 2743 mm size (5.0" x 108") Suits 152 - 406 mm (6" - 16") Pipe Diameter	1	1

## Lil' Wiz Case



- 1 - Circle wiz # CW-300
- 1 - Combo degree level #L-2
- 1 - Small magnetic centering head #53025-M
- 1 - Magnetic tape holder # 89754
- 1 - Flange wizard tools catalogue
- 1 - FREE vial repair kit # 5102

Part No.	Description	Pur.	Pk
8915	Lil' wiz case	1	1

## Buckle Strap



A spring buckle strap used to hold the base tight on non magnetic work materials.

Part No.	Description	Pur.	Pk
5010W	Strap with spring	1	1

## Square

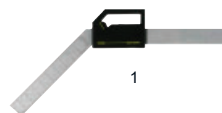

- Lightweight
- Handles up to 200 mm (8") flanges and up to 350 mm (14") fittings
- Versatile for measuring 45° and 90° angles

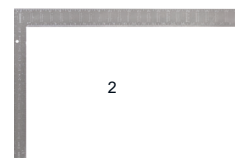

- Highly visible lettering and rust resistant finish
- Marked with both imperial and metric units

Part No.	Description	Pur.	Pk
1 790000	Mul-t-square	1	1
790030	Mul-t-square w/ extended blade	1	1
2 781921	Standard square - aluminium	1	1

# PIPE WELDING

## Modified Square

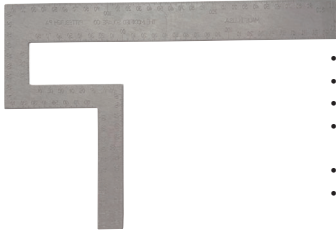

3 points of centering T-square effect (4-90 degree angles)

- Tri-square effect
- Handle-like squaring
- Regular squaring
- Measures height and depth simultaneously
- Squares pipe flanges in two moves
- Ability to square around an over-hanging edge

Part No.	Description	Pur.	Pk
6629	Modified square metric	1	1

## Magnetic Tape Holder



This tool is machined from aluminium and anodized for a protective finish. A strong 11 kgs (25 lbs) pull magnet set in epoxy secures the tape holder to your work.

Part No.	Description	Pur.	Pk
89754W	Magnetic tape measure holder	1	1

## Magnetic Blocks On/Off



Each set comes with 2 ON/OFF magnetic blocks. Each 27 kg (60 lb.) magnetic block can be attached to any standard square or straight edge (up to 38 mm (1/8") thick) to form your own burning guides. Blocks are machined aluminum and have thumb screws to easily adjust blocks on straight edges or squares.

Part No.	Description	Pur.	Pk
MSB202	Magnetic blocks set of 2	1	1
MSG230	Magnetic on/off torch blocks	1	1

## Magnetic Circle Lay & Burning Guide



As a circle layout tool, will cut circles as small as 50 mm (2") out of the base and up to 760 mm (30") in diameter in the base.

As a circle burning guide use this same tool to cut a round plate.

Part No.	Description	Pur.	Pk
28439W	Magnetic circle lay & burn guide	1	1

## Magnetic Holder



Used to position a standard builders square for layout work or to create an ideal burning guide. Holds squares up to 3 mm (1/8") thick.

Part No.	Description	Pur.	Pk
781895	Magnetic holder (3 pk)	1	1



# PIPE WELDING

## Magnetic Torch Guide



This 610 mm (24") stainless steel straight edge rail comes with strong, heat resistant, adjustable, magnetic blocks that can be positioned to accommodate any cutting job.

Part No.	Description	Pur.	Pk
23040-W	Magnetic torch guide 610 mm cutting rail w/ 2 adjustable magnetic holding blocks	1	1

## Chariot Cutting Guide



Chariot cutting guide will cut circles up to 990 mm (39") in diameter, can bevel circles up to 910 mm (36") in diameter, and cut straight, irregular shapes, circles.

Part No.	Description	Pur.	Pk
24219CBG	Beveling chariot burning guide	1	1

## Burning Guide



1

Reach into corners and tight places. Torch tip can actually get right into corner and have a single wheel stand-off to keep the tip at a proper distance from the work surface. The wheel can be rotated to be used with a straight edge guide. Cuts holes from 15.8 - 609 mm (5/8" to 24") diameter. Designed with a universal bushing, it fits any conventional torch tip.

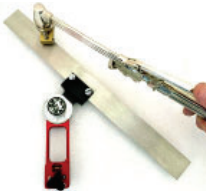

2

The Angle Burning Guide with Magnetic Base is for use with conventional or plasma torch to assist in making excellent angle or straight cuts every time. Be used as a protractor or multi-angle tri-square. Guide will hold any standard square as well as most straight edges. The ON/OFF switch makes setting up easy and keeps the block free from debris.

Part No.	Description	Pur.	Pk
1	SBG301 Burning guide standard	1	1
2	ABG750 Burning guide multi use angle	1	1

## Plasma Wiz w/ Bushing



1

Quality product designed to make your hole cutting jobs in steel and nonferrous metals a snap. The plasma wiz will cut holes from 15.8 mm to 200 mm (5/8" to 8") in diameter without any wheels.



2

Kit includes:

- Aluminum Body
- 1 x Thumb Screw 1/4-20 x 1/2" w/ shoulder
- 2 x Stand-off Screw 1/4-20 x 1.00'
- 2 x Adjusting Screw 1/4-20 x 1/2'

Part No.	Description	Pur.	Pk
1	30061-1.200-W Plasma wiz w/ bushing 61-1.200	1	1
	30061-1.275-W Plasma wiz w/ bushing 61-1.275	1	1
	77350-W Plasma guide base (suction cup)	1	1
2	6201 Plasma beveling yoke	1	1

## Multi Trammel Heads



Using standard half inch pipe as a trammel bar, heads feature radius set points cast in alignment with marking pointers for easy setting.

Part No.	Description	Pur.	Pk
C0721-0016	Multi trammel heads (14785)	1	1

## Circle Wiz



The circle wiz cutting attachment is for cutting small to medium holes in plate or pipe. It is especially handy for cutting out the holes for matching saddle cuts, weldolets and threadolets.

Part No.	Description	Pur.	Pk
CW300W	Circle Wiz	1	1

# PIPE WELDING

## Inflatable Purge Star Dam

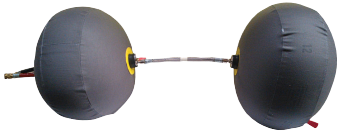

- Purge 150 mm (6") pipe in less than 3 minutes to less than 1% oxygen content
- Reduce argon usage
- Increase weld production rate
- Improve weld quality
- Now with faster inflation time
- Made with the best quality material for years of use

Part No.	Description	Pur.	Pk
786000	Inflatable purge star 50 mm (2")	1	1
786001	Inflatable purge star 75 mm (3")	1	1
786002	Inflatable purge star 100 mm (4")	1	1
786003	Inflatable purge star 150 mm (6")	1	1
786004	Inflatable purge star 200 mm (8")	1	1
786005	Inflatable purge star 250 mm (10")	1	1
786008	Inflatable purge star 400 mm (16")	1	1

## Inflatable Purge System



- Made from fire-retardant "Flameshield" proban cotton for increased resistance to damage from scorching and burning.
- Armoured, robust connection hose.
- Bypass hose for additional gas inlet/exhaust.
- Reinforced stitching and crimping for improved tear resistance.
- Strong eyelet pull loops.
- Reduces flow rate during hot passes to 5 - 10 lpm.
- Available for pipe diameters from 50 mm - 2438 mm (2" - 96").
- Special hose barb connections available for easy connection to gas source.

Part No.	Description	Pur.	Pk
TMIPS002	Inflatable purge 50 mm (2")	1	1
TMIPS003	Inflatable purge 75 mm (2 15/16")	1	1
TMIPS004	Inflatable purge 100 mm (3 15/16")	1	1
TMIPS005	Inflatable purge 120 mm (4 3/4")	1	1
TMIPS006	Inflatable purge 150 mm (5 15/16")	1	1
TMIPS008	Inflatable purge 200 mm (7 7/8")	1	1
TMIPS010	Inflatable purge 250 mm (9 13/16")	1	1
TMIPS012	Inflatable purge 300 mm (11 13/16")	1	1
TMIPS014	Inflatable purge 350 mm (13 3/4")	1	1
TMIPS016	Inflatable purge 400 mm (15 3/4")	1	1
TMIPS018	Inflatable purge 450 mm (17 3/4")	1	1
TMIPS020	Inflatable purge 500 mm (19 11/16")	1	1
TMIPS022	Inflatable purge 550 mm (21 5/8")	1	1
TMIPS024	Inflatable purge 600 mm (23 5/8")	1	1
TMIPS026	Inflatable purge 650 mm (25 9/16")	1	1
TMIPS030	Inflatable purge 750 mm (29 1/2")	1	1
TMIPS040	Inflatable purge 1000 mm (39 3/8")	1	1

## Inflatable Ring Purge



- Double hose inflation:  
Red for dam inflation.  
Black to fill the weld chamber
- Exclusive dam dump valve deflates dam quickly after weld is completed
- High temperature resistant Proban & fire resistant fabrics
- Dramatic savings in argon
- High quality weld results
- Designed for years of use

Part No.	Description	Pur.	Pk
786021	Inflatable ring purge 1050 mm (42")	1	1

## Nitrile Inflatable Blanking Stoppers



- Inflatable stoppers designed for sealing inside pipes for gas purging and low pressure testing applications manufactured in the UK to ISO standards.
- Sizes ranging from 50 mm to 2520 mm (2" - 99 3/16")
- Resistant to most chemicals, gases and oils as well as having good abrasion resistance.
- Constructed with a latex inner bladder, with a nitrile outer case with a coated seam.

Part No.	Description	Pur.	Pk
TMNIBS030	Nitrile inflatable blanking stopper	1	1

## Purge Buddy



- Heavy duty polyester / cotton impregnated with canvas material
- Latex bladder
- Pull loops for inside of pipe
- 1.5 m / 4.8 ft inflation hose

Part No.	Description	Pur.	Pk
786084	Purge buddy 150 mm pipe size (6")	1	1

# PIPE WELDING

## Pro Kit Tuber & Pipe Notcher



- Kit includes
- Tube & pipe notcher
  - T-post clamp with v-pad
  - Aluminum v-blocks x 2
  - Round stock pliers
  - Locating stops x 2
  - V-block spacers x 2
  - Threaded hole adaptor
  - Flush mounting bolts x 4

Notching a round, or square tube or pipe has never been easier. Do quick and consistent notches on straight, angled and curved tubes with complex angles. The new BuildPro® Tube & Pipe Notcher makes alignment and length control of the notch easy!

- Heavy duty, all steel construction
- Cuts notches in 1" - 2-1/2" O.D tubing.
- Adjust cutting angle up to 90°

Part No.	Description	Pur.	Pk
AZPN	Pro kit tuber and pipe notcher	1	1

## Purge Baffle Kits

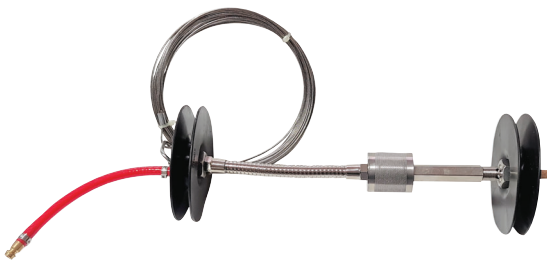

- Kit includes:
1. Gas inlet with nut & safety hook
  2. Gas outlet with nut & sintered excess pressure vent
  3. 9 m pull cable & 9 m gas hose with quick disconnect
  4. Ridge arms 2 x medium, 1 x short
  5. Flexible arm x 1
  6. Gas diffuser x 1
  7. Silicon baffles x 2



Durable tube and pipe baffle systems are designed for quick, cost effective purging of popular pipe and tube diameters and schedules. They're engineered to reduce time spent purging a run of pipe, and greatly decrease labor costs, and save you money on expensive argon shield gas. Most importantly, purge baffles are proven to improve tube and pipe weld quality.

Based on your application, choose between our heavy-duty, dedicated Purge Baffles designed for a single pipe diameter, or choose a versatile Modular Baffle System which includes a variety of interchangeable parts that can be customized to handle all of the pipe diameters and schedules that come your way.

Part No.	Description	Pur.	Pk
AZPK3843	Purge baffle kit 38 - 43 mm	1	1
AZPK4348	Purge baffle kit 43 - 48 mm	1	1
AZPK4753	Purge baffle kit 47 - 53 mm	1	1
AZPK5258	Purge baffle kit 52 - 58 mm	1	1
AZPK5463	Purge baffle kit 54 - 63 mm	1	1
AZPK5868	Purge baffle kit 58 - 68 mm	1	1
AZPK6472	Purge baffle kit 64 - 72 mm	1	1
AZPK6876	Purge baffle kit 68 - 76 mm	1	1
AZPK7281	Purge baffle kit 72 - 81 mm	1	1
AZPK7586	Purge baffle kit 75 - 86 mm	1	1
AZPK8091	Purge baffle kit 80 - 91 mm	1	1
AZPK8695	Purge baffle kit 86 - 95 mm	1	1
AZPK90101	Purge baffle kit 90 - 101 mm	1	1
AZPK100112	Purge baffle kit 100 - 112 mm	1	1
AZPK105120	Purge baffle kit 105 - 120 mm	1	1
AZPK120140	Purge baffle kit 120 - 140 mm	1	1
AZPK135155	Purge baffle kit 135 - 155 mm	1	1
AZPK145165	Purge baffle kit 145 - 165 mm	1	1
AZPK160180	Purge baffle kit 160 - 180 mm	1	1
AZPK175200	Purge baffle kit 175 - 200 mm	1	1
AZPK195220	Purge baffle kit 195 - 220 mm	1	1
AZPK215240	Purge baffle kit 215 - 240 mm	1	1

Part No.	Description	Pur.	Pk
AZPK235260	Purge baffle kit 235 - 260 mm	1	1
AZPK255280	Purge baffle kit 255 - 280 mm	1	1
AZPK275300	Purge baffle kit 275 - 300 mm	1	1
AZPK290320	Purge baffle kit 290 - 320 mm	1	1
AZPK310340	Purge baffle kit 310 - 340 mm	1	1
AZPK325355	Purge baffle kit 325 - 355 mm	1	1
AZPK345375	Purge baffle kit 345 - 375 mm	1	1
AZPK360390	Purge baffle kit 360 - 390 mm	1	1
AZPK380410	Purge baffle kit 380 - 410 mm	1	1

# PIPE WELDING

## Purge Baffle Spare Parts



Part No.	Description	Pur.	Pk
1	AZRB3843	Purge baffle 38 - 43mm	1 1
	AZRB4348	Purge baffle 43 - 48mm	1 1
	AZRB4753	Purge baffle 47 - 53mm	1 1
	AZRB5258	Purge baffle 52 - 58mm	1 1
	AZRB5463	Purge baffle 54 - 63mm	1 1
	AZRB5868	Purge baffle 58 - 68mm	1 1
	AZRB6472	Purge baffle 64 - 72mm	1 1
	AZRB6876	Purge baffle 68 - 76mm	1 1
	AZRB7281	Purge baffle 72 - 81mm	1 1
	AZRB7586	Purge baffle 75 - 86mm	1 1
	AZRB8091	Purge baffle 80 - 91mm	1 1
	AZRB8695	Purge baffle 86 - 95mm	1 1
	AZRB90101	Purge baffle 90 - 101mm	1 1
	AZRB100112	Purge baffle 100 - 112mm	1 1
	AZRB105120	Purge baffle 105 - 120mm	1 1
	AZRB120140	Purge baffle 120 - 140mm	1 1
	AZRB135155	Purge baffle 135 - 155mm	1 1
	AZRB145165	Purge baffle 145 - 165mm	1 1
	AZRB160180	Purge baffle 160 - 180mm	1 1
	AZRB175200	Purge baffle 175 - 200mm	1 1
	AZRB195220	Purge baffle 195 - 220mm	1 1
	AZRB215240	Purge baffle 215 - 240mm	1 1
	AZRB235260	Purge baffle 235 - 260mm	1 1
	AZRB255280	Purge baffle 255 - 280mm	1 1
	AZRB275300	Purge baffle 275 - 300mm	1 1
	AZRB290320	Purge baffle 290 - 320mm	1 1
	AZRB310340	Purge baffle 310 - 340mm	1 1
	AZRB325355	Purge baffle 325 - 355mm	1 1
	AZRB345375	Purge baffle 345 - 375mm	1 1
	AZRB360390	Purge baffle 360 - 390mm	1 1
	AZRB380410	Purge baffle 380 - 410mm	1 1
2	AZSINVENT	Sintered pressure vent	1 1
3	AZ MAXIFLOW 1	Maxi flow system #1	1 1
	AZ MAXIFLOW 2	Maxi flow system #2	1 1
4	AZFLEXARM	Flexi arm	1 1
5	AZLC9M	Lanyard 9.1m 1.6mm stainless steel	1 1

## Tube Purging Kit



- Quickly Purge any Size Pipe in 2 Minutes - Saves Time & Gas!
- Reduce Purge Time from Hours to 2 Minutes!
- Dramatically Reduce Argon Consumption up to 94%!
- High Temperature Components 329°C (625°F) - No Melting or Bursting of Bladders.
- Diffuser Distributes Gas - No Turbulence means Better Weld Quality.
- Flexible Connections Included - Not Just Straight Pipe Runs but also Elbows can be Purged.
- Non Contaminating & Halogen Free - Nuclear & Food Safe.

Part No.	Description	Pur.	Pk
AZTPK25100	Tube Purging Kit 25 - 100 mm	1	1

## Purge Baffle Kit



Part No.	Description	Pur.	Pk
AZMPK1619	Purge baffle kit mini 16 - 19 mm	1	1
AZMPK1924	Purge baffle kit mini 19 - 24 mm	1	1
AZMPK2429	Purge baffle kit mini 24 - 29 mm	1	1
AZMPK2934	Purge baffle kit mini 29 - 34 mm	1	1
AZMPK3438	Purge baffle kit mini 34 - 38 mm	1	1
AZMPK3843	Purge baffle kit mini 38 - 43 mm	1	1
AZMPK4348	Purge baffle kit mini 43 - 48 mm	1	1

# PIPE WELDING

## Purge Kit



- Fast purge times for pipes, elbows and fittings
- High quality white nitrile discs
- Includes both flexible and rigid purge rods manufactured from lightweight aluminum for strength and durability
- Insulated steel cable with stainless steel swivel bolt snap
- 10 m Purge hose with brass flow meter fitting at one end and purge pipe fitting on the other end
- Replacement discs can be manufactured quickly and cost effectively to meet size requirements.

Part No.	Description	Pur.	Pk
FDKT40-300	Purge kit 40 - 300 mm	1	1
FDRT40-150	Foam rubber tube pack 40 - 150 mm	1	1
FDRT40-300	Foam rubber tube pack 40 - 300 mm	1	1
FDRT200-300	Foam rubber tube pack 200 - 300 mm	1	1
FDKP40-300SCH10	Purge kit pipe 40 - 300 mm SCH10	1	1
FDRP40-150SCH10	Foam rubber pipe pack 40-150 mm SCH10	1	1
FDRP40-300SCH10	Foam rubber pipe pack 40 - 300 mm SCH10	1	1
FDRP200-300SCH10	Foam rubber pipe pack 200 - 300 mm SCH10	1	1
FDKP40-300SCH40	Purge kit pipe 40 - 300 mm SCH40	1	1
FDRP40-150SCH40	Foam rubber pipe pack 40-150 mm SCH40	1	1
FDRP40-300SCH40	Foam rubber pipe pack 40 - 300 mm SCH40	1	1
FDRP20-300SCH40	Foam rubber pipe pack 200 - 300 mm SCH40	1	1

## Nylon Expansion Kits

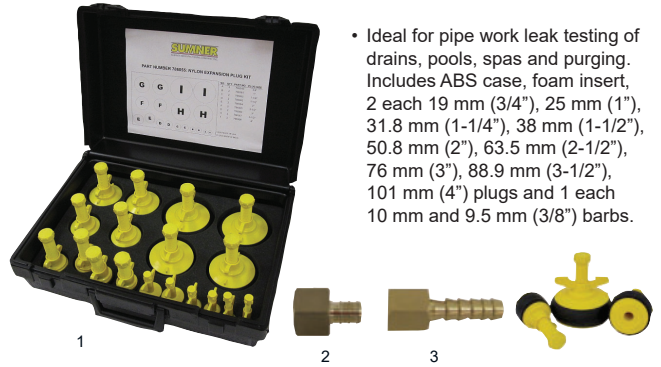

- Ideal for pipe work leak testing of drains, pools, spas and purging. Includes ABS case, foam insert, 2 each 19 mm (3/4"), 25 mm (1"), 31.8 mm (1-1/4"), 38 mm (1-1/2"), 50.8 mm (2"), 63.5 mm (2-1/2"), 76 mm (3"), 88.9 mm (3-1/2"), 101 mm (4") plugs and 1 each 10 mm and 9.5 mm (3/8") barbs.

Part No.	Description	Pur.	Pk
1 786055	Expansion plug nylon kit 17 mm - 100 mm (3/4" - 4")	1	1
2 779396	Hose barb 10 mm	1	1
3 779395	Hose barb 9.525 mm (3/8")	1	1
4 786060	Expansion plug nylon 17 mm (3/4")	1	1
786061	Expansion plug nylon 25 mm (1")	1	1
786062	Expansion plug nylon 31 mm (1-1/4")	1	1
786063	Expansion plug nylon 37 mm (1.5")	1	1
786064	Expansion plug nylon 50 mm (2")	1	1
786065	Expansion plug nylon 60 mm (2.5")	1	1
786066	Expansion plug nylon 75 mm (3")	1	1
786067	Expansion plug nylon 85 mm (3-1/2")	1	1
786068	Expansion plug nylon 100 mm (4")	1	1
786070	Expansion plug nylon 150 mm (6")	1	1

## Aluminium Pipe Stopper



Aluminium plugs are the ideal tool for sealing pipes for plumbing operations and to avoid the penetration of debris and other contamination in a pipe.

The natural rubber seals of the standard aluminium plugs are expanded by tightening a wing nut once the plug has been positioned inside the pipe.

Part No.	Description	Pur.	Pk
TMASC01	Aluminium pipe stopper 40 mm (1 9/16")	1	1
TMASC05	Aluminium pipe stopper 125 mm (4 15/16")	1	1



# PIPE WELDING

## Alumtape



1

- Aluminium heat resistant welding tape.
- Seals root gaps while purging.
- Minimal inert gas loss during purging.
- Seals pipe ends for transporting.
- Helps prevent heat and cooling loss.
- Aggressive adhesive.
- Minimize the need for post-weld grinding and cleaning.



2

- Aluminium purge zone tape



3

- Fibreglass weld backing tape
- Complete fusion weld on pipe and sheet metal
- Suitable for military ship and submarine manufacturing, general fabrication, pipeline welding, aircraft, general maintenance, pressure vessels.

Part No.	Description	Pur.	Pk
1	ALUMTAPE 1 mm x 50 mm x 25 m (3/64" x 2" x 82 ft)	1	1
2	EZ-ZT2.5 1 mm x 64 mm x 23 m (3/64" x 2 1/2" x 75 ft)	1	1
	EZ-ZT4.0 1 mm x 100 mm x 246 m (3/64" x 3 15/16" x 807 ft)	1	1
3	AFBT-2.5-200 1 mm x 64 mm x 25 m (3/64" x 2 1/2" x 82 ft)	1	1
	AFBT-2.5 1 mm x 64 mm x 12.5 m (3/64" x 2 1/2" x 41 ft)	1	1
	AFBT-40 1 mm x 102 mm x 12.5 m (3/64"x 4" x 41 ft)	1	1

## Self Adhesive Water Soluble Paper



1

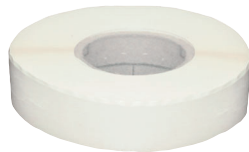

2

Part No.	Description	Pur.	Pk
1	TM-2303T 50 mm x 91 m (2" x 298') roll	1	1
2	TM-1303T 25 mm x 91 m ( 1" x 298') roll 76 mm (3") core	1	1

## Water Soluble Paper Light Weight



1



2

- Cost effective option for single welds
- Easy set-up and handling
- Soluble in hot and cold water for easy removal

Part No.	Description	Pur.	Pk
1	TM35-811S 216 mm x 279 mm (8 1/2" x 11") sheet	250	250
	TM35-814S 126 mm x 368 mm (5" x 14 1/2") sheet	250	250
2	TM35-9165R 225 mm x 50 m (9" x 164') roll	1	1
	TM35-15165R 375 mm x 50 m (14 3/4" x 164') roll	1	1
	TM40-20165R 500 mm x 50 m (19 11/16" x 164') roll	1	1

## Water Soluble Paper Heavy Weight



1



2

- Cost effective option for single welds
- Easy set-up and handling
- Soluble in hot and cold water for easy removal

Part No.	Description	Pur.	Pk
1	TM60-1522S 394 mm x 559 mm (15 1/2" x 22") sheet	50	50
2	TM60-15165R 394 mm x 50 m (15 1/2" x 164') roll	1	1
	TM60-31165R 787 mm x 50 m (31" x 164') roll	1	1

## EZ Wipes



- Shred resistant & lint free two sided cleaning system
- Abrasive side loosens & removes dried on surface contaminants.
- Smooth side completes the process by removing remaining particles to reveal a clean & polished surface.

Part No.	Description	Pur.	Pk
EZW	Aquasol ez wipes	1	1

# PIPE WELDING

## Argone Weld Gas Analyser Self Calibrating



- Self calibration
- Accurately displays oxygen content from 20.90% - 0.01%.
- Easy operation & light weight.
- Ideal for on site use.
- Quick response to changes in oxygen levels.
- Kit includes: case, lanyard, flow adaptor, aspirator bulb, 2 m (6 ft) rubber hose & steel probe, manual & calibration certificates.

1



2



3



4

Part No.	Description	Pur.	Pk
1	TMGASC Argone weld gas analyser self calibrating	1	1
2	TMSCS Red sensor self calibrating	1	1
3	TMRH001 Rubber hose 2 m	1	1
4	TMSC-HP Probe with hose	1	1

## Argo-Naught Oxygen Analyser



- Includes
- Case
  - Argo-Naught Analyser
  - 9-volt battery
  - 2 m (6-1/2 ft) rubber hose
  - Stainless steel probe
  - Rubber vacuum bulb

Part No.	Description	Pur.	Pk
779281	Argo-Naught oxygen analyser	1	1

## Oxygen Monitor



1

2

The most advanced and CE approved oxygen monitoring device, the PRO OX-100B not only measures oxygen content down to 100 PPM (0.01%) during the purging process, but is equipped with a bluetooth transmitting device that allows the oxygen monitor to send the oxygen readings wirelessly to a bluetooth receivable device, operators may view the readings from a remote location.



3

Compatible with Android, iOS and Windows. The APP allows users to monitor oxygen levels within a range of 30 mtr from the actual oxygen monitor with Bluetooth transmitting capabilities. Real-time monitoring improves the quality control process and improves productivity.

The PROOX5B is a battery-powered, Bluetooth transmitting, rechargeable, handheld digital oxygen monitor with an internal pump that accurately measures oxygen concentration with 0.005% (5 PPM) resolution. Oxygen is displaced by the purge gas to a pre-determined level set by the operator. Evacuation of oxygen is paramount in high purity welding to prevent oxidation, discoloration, and coking.

Part No.	Description	Pur.	Pk
1	POM100B Pro Ox-100b oxygen monitor	1	1
2	P-OX Sensor	1	1
3	POM5B Pom Ox-5b 5ppm oxygen monitor	1	1

# PIPE WELDING

## Fab Kit - Mathey Dearman

Safe, fast, and effective solution for even the toughest flange alignment jobs. The tool's tapered shaft eliminates hammering and prying when lining up flange bolt holes.



FAB Kit Containing 1 Set of:  
3/4", 7/8", 1", 1 1/8", 1 1/4" & 1 3/8"

Part No.	Description	Pur.	Pk
FBK	Flange bolt kit	1	1

## Tri Chain Vise Stand



- A simple but effective solution to small bore pipe handling
- Pipe Size Capacity: 1.27 cm - 15 cm (1/2" - 6")
- Height: 91cm (36")

Part No.	Description	Pur.	Pk
6100	Tri stand chain vise	1	1

## Step Wedge



- Two tools in one. Wedge and gauge.
- Pull or push for gap width adjustments.
- Allows full line of sight during fit-up.
- Unique hole allows fall protection lanyard and wedge extraction.
- Landings can be measured quickly and accurately.
- Can be used with a standard wedge or alone.
- Efficient and easy to use.

Part No.	Description	Pur.	Pk
2130	Step wedge stainless 100 mm	1	1
2131	Step wedge stainless 150 mm	1	1

## Trailing Shield



- Suitable for any sheet and plate metal applications
- Suitable for all reactive metals
- Reduce gas use and weld oxidation
- Helps produce clean, oxygen-free welds

Part No.	Description	Pur.	Pk
TMTSS01	Flat trailing shield	1	1

## Portable Tungsten Grinder



- Light weight, easy to use and portable.
- Integrated exhaust with replaceable dust filter.
- Grinds quality points on tungsten electrodes.
- Able to grind electrodes as short as 8-15 mm (5/16" - 9/16").
- See-through cover allows inspection of grinding operation.
- Adjustment of grinding position on wheel triples diamond wheel life expectancy.

1



2

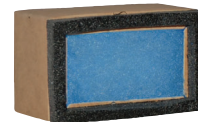

3



4



5

6

Part No.	Description	Pur.	Pk
1	TMPTG01 Tungsten grinder portable 220 volt w/ integrated extraction	1	1
2	TMPTG03 Diamond wheel 40 mm (1 9/16") diameter	1	1
3	TMPTG18 Filter cassette	1	1
4	TM16.2 Neutrix electrode chuck 1.6 mm (1/16")	1	1
	TM16.4 Neutrix electrode chuck 2.4 mm (1/16")	1	1
	TM16.5 Neutrix electrode chuck 3.2 mm (1/8")	1	1
5	TMS074 Motor brush (pair)	1 PR	1 PR
6	TMPT04 Spindle	1	1

# PIPE WELDING

## Cricket



- 450 kgs (992 lbs) & 6.1 m (20 ft) transporting capacity
- Carries up to 304 mm (12") diameter pipe
- Quick handle disconnect for compact storage
- Includes hold down strap
- 406 mm (16") tubed tyres
- Carries up to 300mm (12") diameter pipe

Part No.	Description	Pur.	Pk
1	782699 Cricket assembly	1	1
	782685 Cricket w/ flat free tyre	1	1
2	779104 Wheel flat free for cricket	1	1
3	779107 Pneumatic tyre & wheel 406 mm (16")	1	1

## Fab Mate

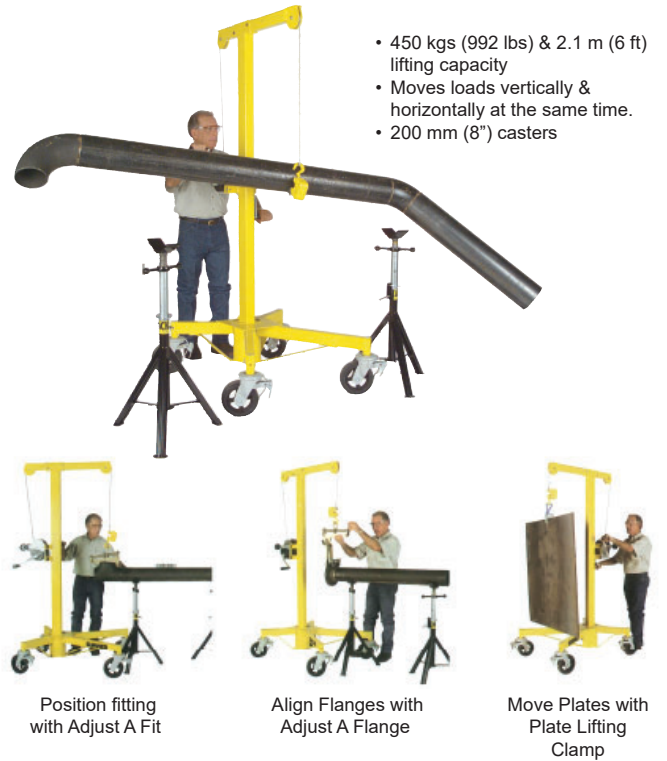

- 450 kgs (992 lbs) & 2.1 m (6 ft) lifting capacity
- Moves loads vertically & horizontally at the same time.
- 200 mm (8") casters

Part No.	Description	Pur.	Pk
783900	Fab mate	1	1

## Grasshopper



- Enables one man to lift 900 kgs (2,000 lbs) unassisted!
- Special sliding chain block design accommodates long and short loads
- Carries up to 500 mm (20") diameter pipe, tool boxes, fittings and valves
- Fits through 890 mm (35") openings, is a versatile 3.6 m (12 ft) long and weighs only 75 kgs (165 lbs)
- Rugged high pressure tires and wheels allow for construction site mobility
- Chains can be used to lock wheels for security

Part No.	Description	Pur.	Pk
780351	Grasshopper	1	1
780521	Wheel 635 mm (25")	1	1

## Pipe Mac



- Transports 900 kg (2,000 lb) of pipe, individually or up to a height of 86 cm (34")
- Six 15 cm (6") heavy duty casters
- Center-positioned casters makes rolling the Pipe Mac easy and enables quick cart rotation for tight turns
- Posts pull out for compact storage
- Stacks when not in use

Part No.	Description	Pur.	Pk
783230	Pipe Mac	1	1